

JD Media Table

Hardware - Table components

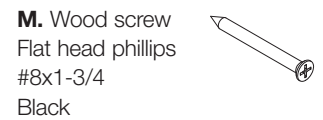

Hardware - Media wall options

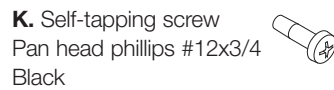
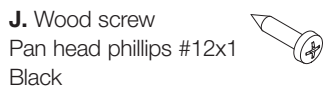
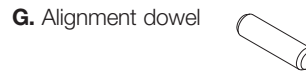
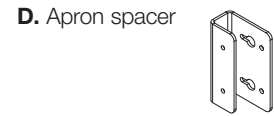
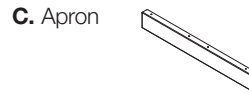
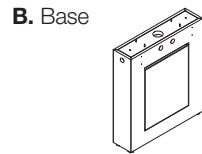
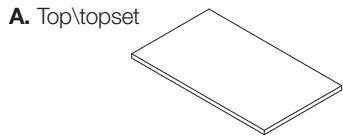
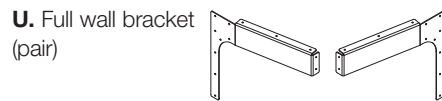
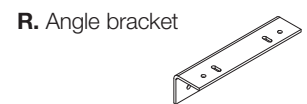
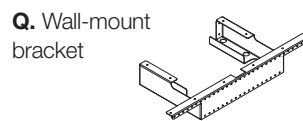
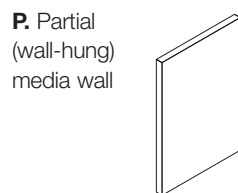
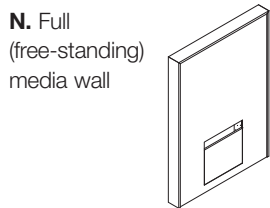

Hardware - Power and connectivity options

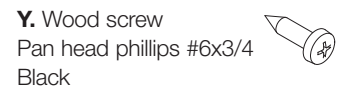
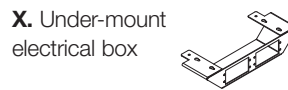
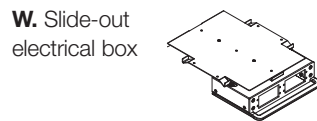
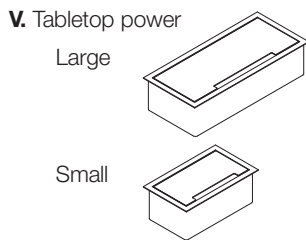

Tools Required

- Cordless drill
- Driver bit, Phillips #2
- Driver bit, Phillips #3
- Driver bit, 4mm hex
- Measuring tape
- Level
- Hammer

JD Media Table

1. Base Assembly

1.1. TABLES WITH 3-1/2" WIDE BASES

- 1.1.1. Prepare apron assembly, attaching apron spacer (D) to one end of all aprons (C) with fasteners (K) oriented as shown in detail A.
 - 1.1.2. Prepare base (B) to attach apron assemblies by loosely attaching fasteners (J) into pilot holes on access door side of base as shown in detail A, stopping about 1/8" short from being completely tightened.
 - 1.1.3. Attach apron assemblies to bases (B) by engaging the keyholes with fasteners (J) loosely attached to bases in the previous step.
- Note:
Bases oriented with access door facing inward.
- 1.1.4. Complete attachment of apron assemblies (C\D) to bases (B) with fasteners (J), making sure all fasteners are now tight.
 - 1.1.5. Insert alignment dowels (G) to bases (B). If the fit is too tight to do by hand, tap gently with a hammer.

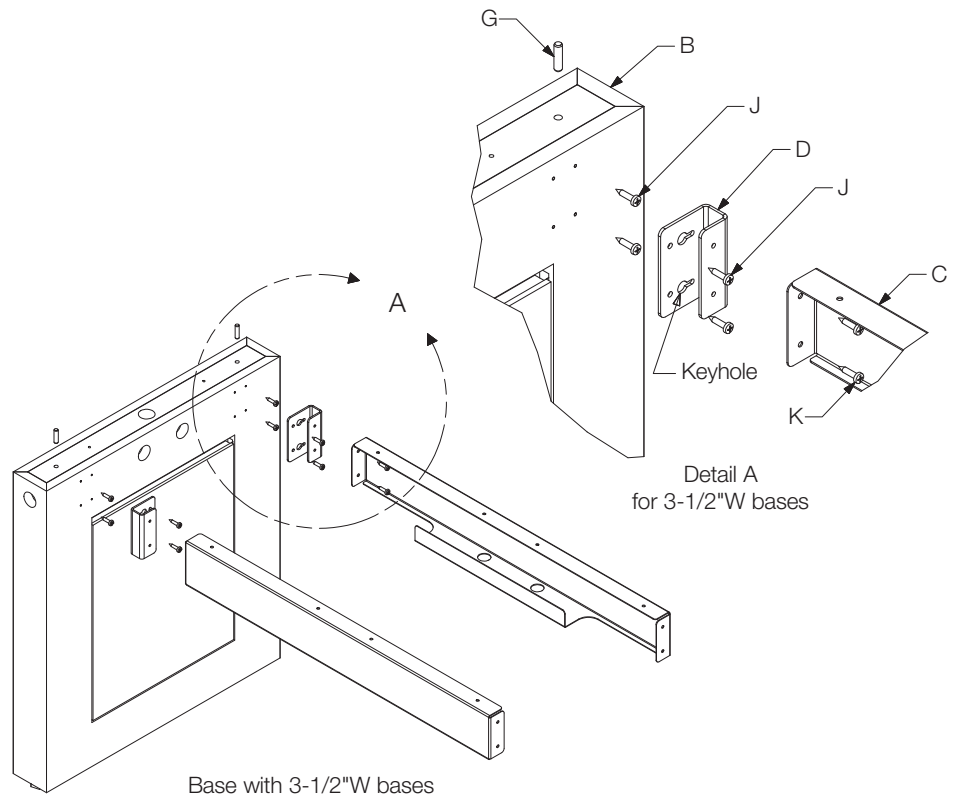

1.2. TABLES WITH 6" WIDE BASES

- 1.2.1. Attach aprons (C) to bases (B) with fasteners (J) on access door side of base as shown in detail B.
- Note:
Bases oriented with access door facing inward.
- 1.2.2. Insert alignment dowels (G) to bases (B). If the fit is too tight to do by hand, tap gently with a hammer.
 - 1.2.3. Base assembly is now complete. Proceed to section 2 for "End Support Attachment".

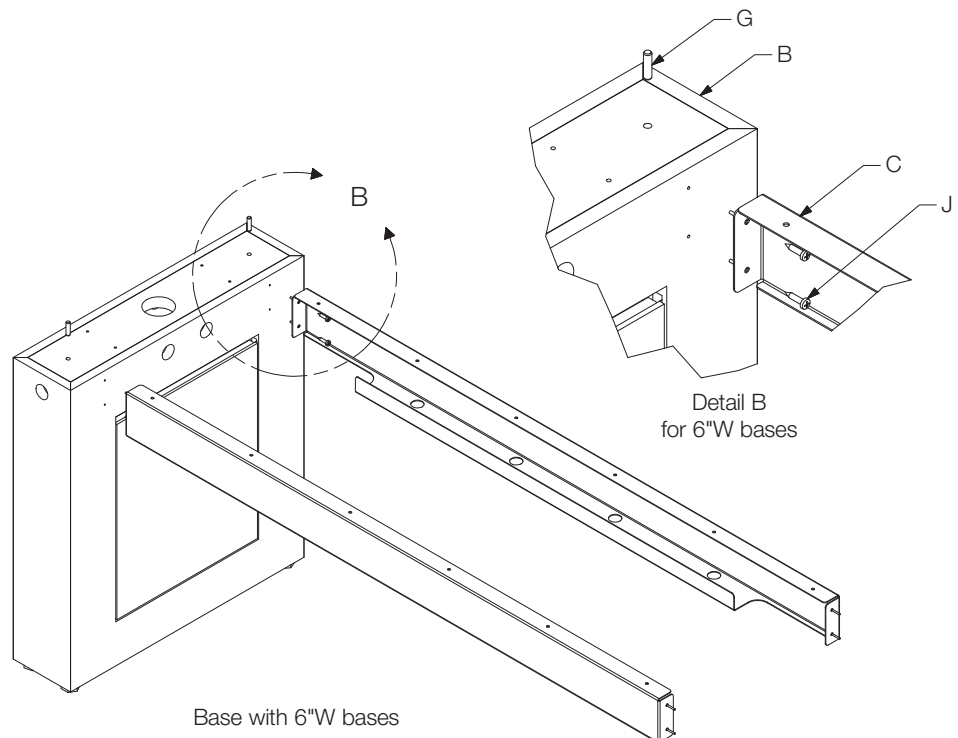

JD Media Table

2. End Support Attachment

2.1. TABLES WITH WALL-MOUNT BRACKET

- 2.1.1. Attach wall-mount bracket (Q) to apron (C) with fasteners (K) oriented as shown in detail C.
- 2.1.2. Using the centre v-notch on the wall-mount bracket as a guide, locate and mark the supporting wall where the table will be attached.
- 2.1.3. With base (B) levelers extended approximately 1/8" (to allow for some adjustability in both directions after attaching to the wall) level and secure the base assembly to the supporting wall using end user supplied fasteners. Once secured to the wall, double-check the level and adjust the base levelers if needed.

Note:

It is the responsibility of the customer and its structural engineer/architect to specify the correct fasteners and method for attaching the table to the supporting wall and to confirm that the installers have adhered to these specifications. For all local building standards and codes, and additional requirements (including, but not limited to, seismic conditions) the customer should always consult local code agencies.

- 2.1.4. End support attachment is now complete. Proceed to section 3 for "Top Assembly".

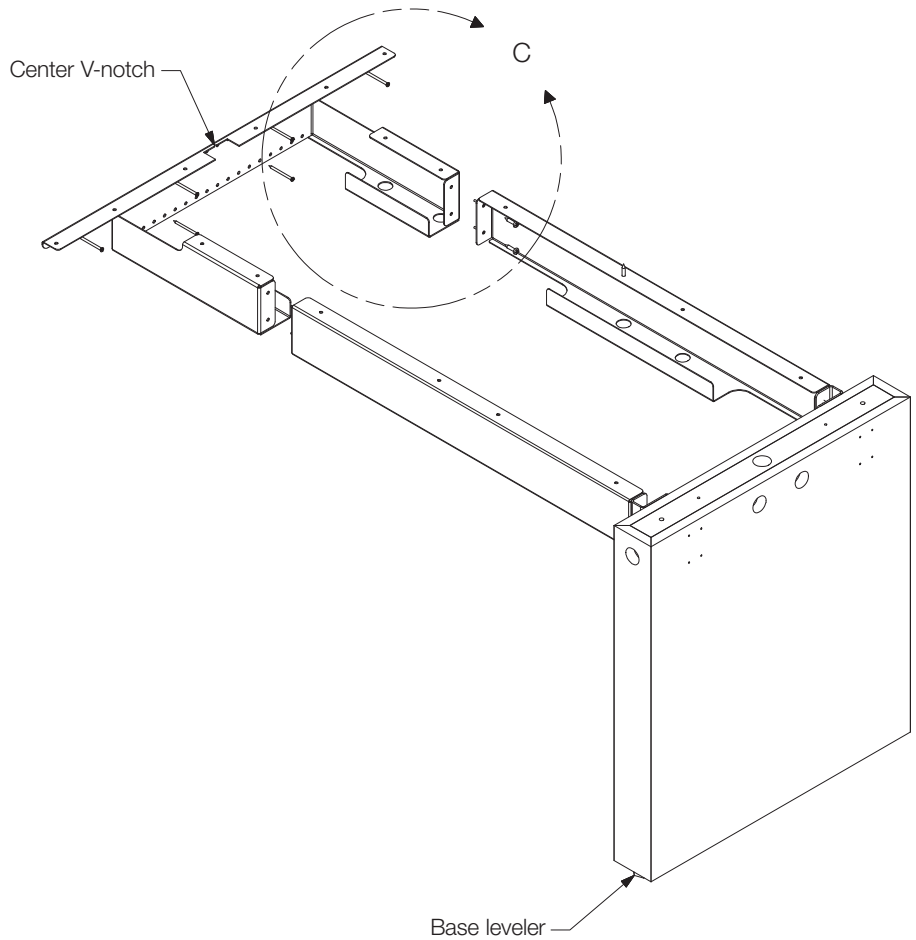

Base with wall-mount bracket

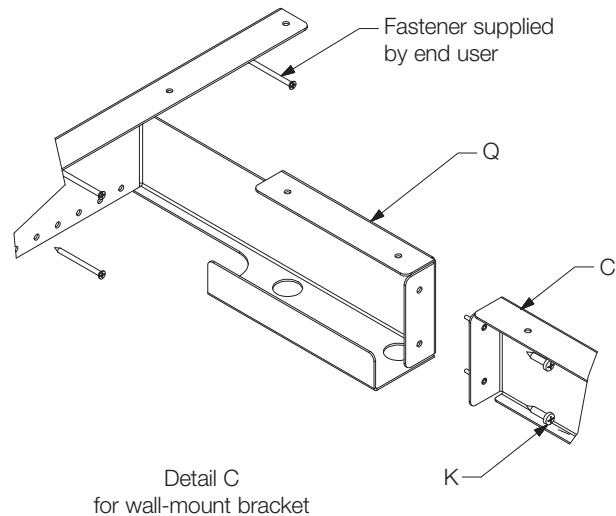

Detail C for wall-mount bracket

JD Media Table

2.2. TABLES WITH FULL (FREE-STANDING) WALL

2.2.1. Attach full wall bracket pair (U) to the inside vertical frame members behind the access door on full wall (N) using fasteners (J) as shown in detail D.

2.2.2. Position full wall assembly where desired then attach base assembly from section 1 connecting the full-wall bracket pair (U) to aprons (C) with fasteners (K) oriented as shown in detail E.

2.2.3. (optional)
Supplied with each full media wall are two (press-fit) round grommets (T) with a 1-9/16" inside clearance used to channel cables from the floor, the ceiling, or both directions at once. Grommets are field installed using a Ø1-3/4" hole saw in the location that best suits the end users application anywhere within the 24" grommet zone centred above the top, as detailed in the illustrations.

2.2.4. (done after top is assembled in section 3 on tops 54"D)
Using field-drilled holes, attach angle bracket (R) to the underside of top (a) and vertical surface of full wall (N) inset about 6" from the edge of the top using fasteners (L) as shown in detail F.

2.2.5. End support attachment is now complete. Proceed to section 3 for "Top Assembly".

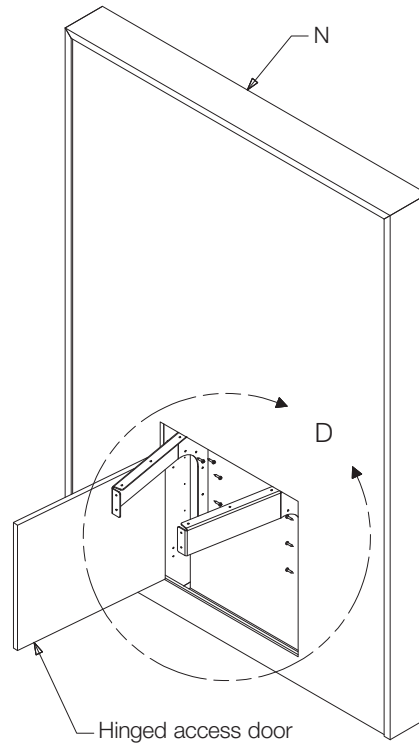

Full wall pre-assembly

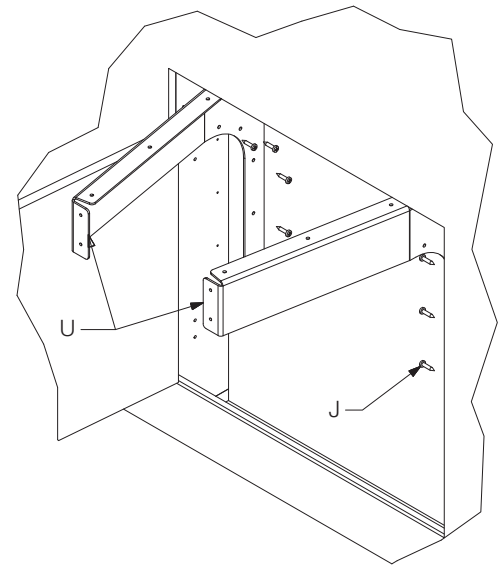

Detail D
Full wall pre-assembly

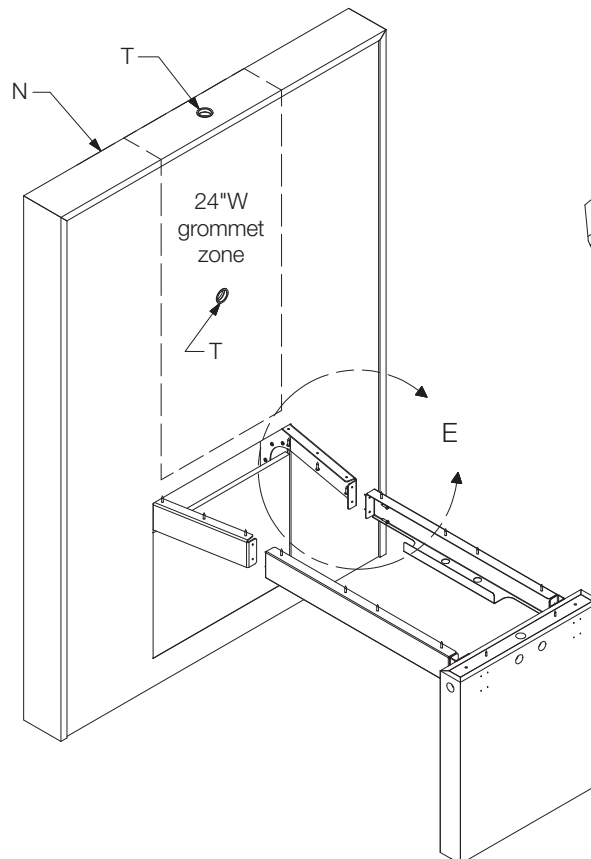

Base and full wall assembly

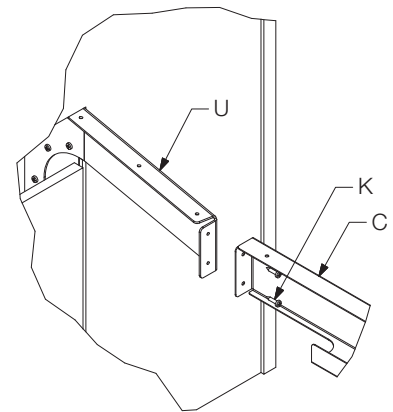

Detail E
Base and full wall assembly

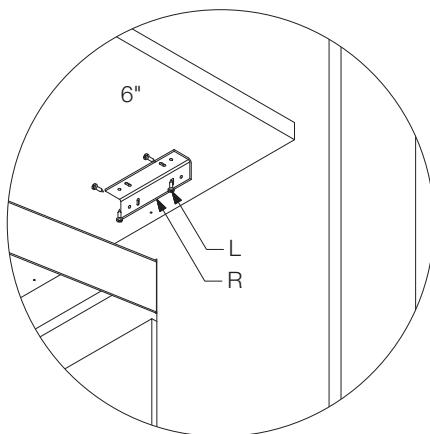

Detail F
(Optional) Angle brackets
done after top assembly

JD Media Table

3 Top Assembly

Before you begin:

Tops are directional. To determine proper orientation look for the two $\varnothing 23/64$ (8 mm) locating dowel holes on the bottom. The end closest to these holes will be the base end and the other will be the wall end.

For 2-pc tops, the one with these locating holes will be the base end piece and the other will be the wall end. Also take care to orient the two sections properly to identify the base and wall edges, if you need to drill an edge grommet as detailed in the next step.

3.1. FIELD DRILLED EDGE GROMMET (OPTIONAL)

Note:

If you are not installing a partial media wall that will require running cables through the top, ignore this step.

3.1.1. On the wall end edge of the top, using a $\varnothing 2$ " hole saw drill a grommet hole centre in depth as shown in detail G.

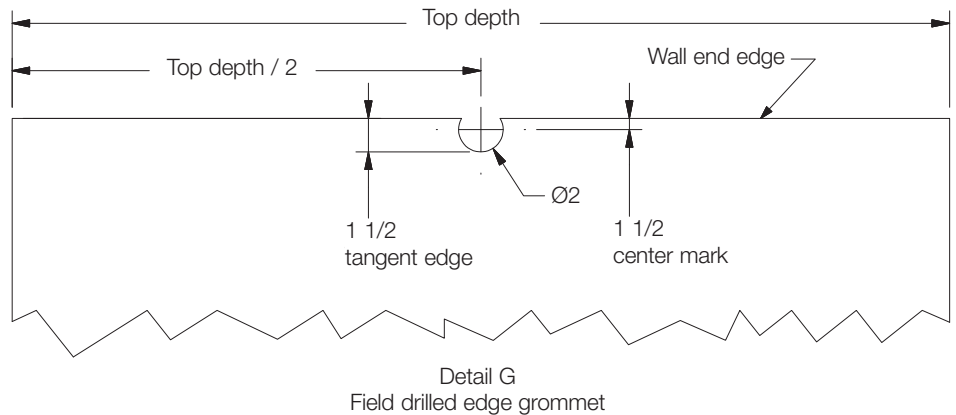

3.2. 1-PIECE TOPS

3.2.1. Place top (A) on base assembly using alignment dowels (G) to properly position it.

3.2.2. Secure top (A) to base assembly with fastener (J) on aprons (C) and fasteners (M) on inside of bases (B) as shown in detail J.

Note:

Use access door to access fastener (M) locations inside bases.

3.2.3. Top assembly is now complete. Proceed to section 4 if installing the optional partial media wall on a wall-hung table or to section 5 for "Power & Connectivity", if this option was selected.

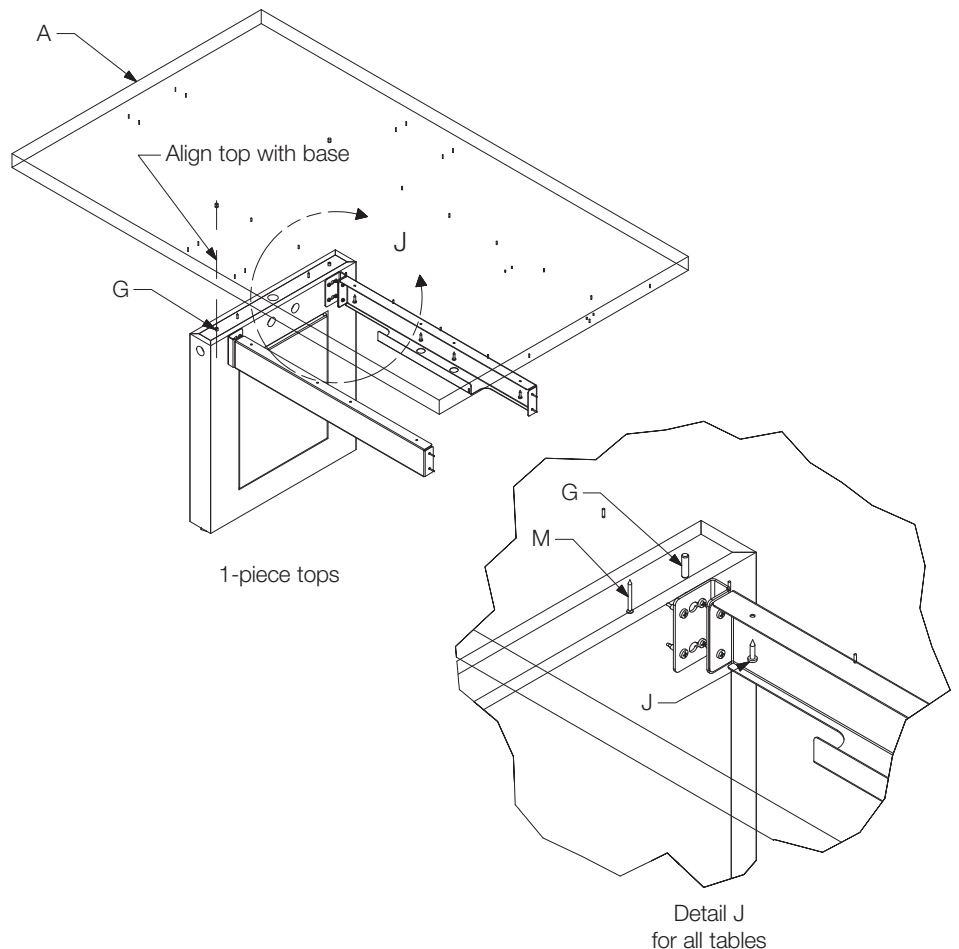

JD Media Table

3.3. 2-PIECE TOPS (TOPSETS)

- 3.3.1. Beginning at the wall support end, loosely place the first top on the base assembly then insert the alignment biscuits (H) into the grooves machined into the connection edge of the top.
- 3.3.2. Using alignment dowels (g) for proper positioning place the second top on the base, taking care to also align and insert biscuits (H) already inserted in the first top. Both pieces should now be properly located.
- 3.3.3. Using zip bolts (F) and a 4mm hex key, tie both pieces together.
- 3.3.4. Using mending plates (E) with fasteners (L), flush the top surface.
- 3.3.5. Secure the topset to the base assembly with fastener (J) on aprons (C) and fasteners (M) on inside of bases (B).

Note:

Use access door to access fastener (M) locations inside bases.

- 3.3.6. Top assembly is now complete. Proceed to section 4 if installing the optional partial media wall on a wall-hung table or to section 5 for "Power & Connectivity", if this option was selected.

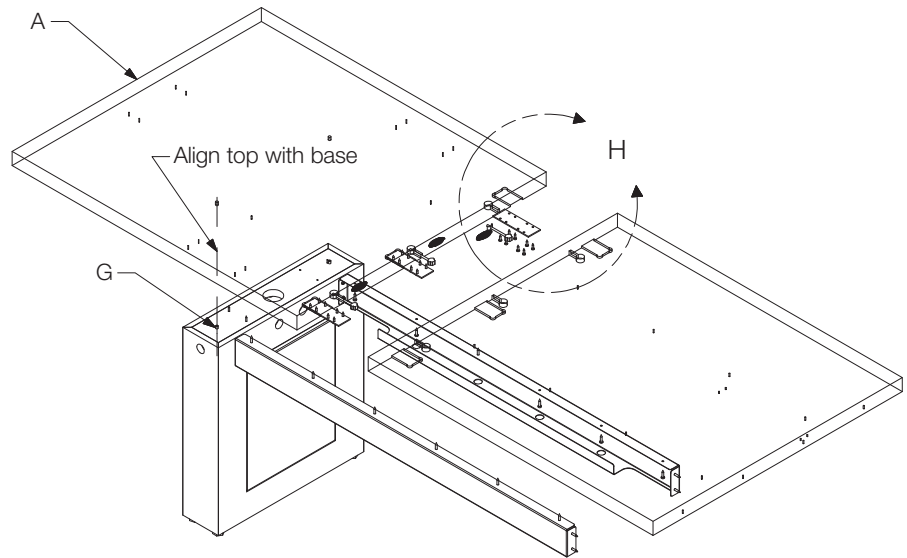

2-piece tops

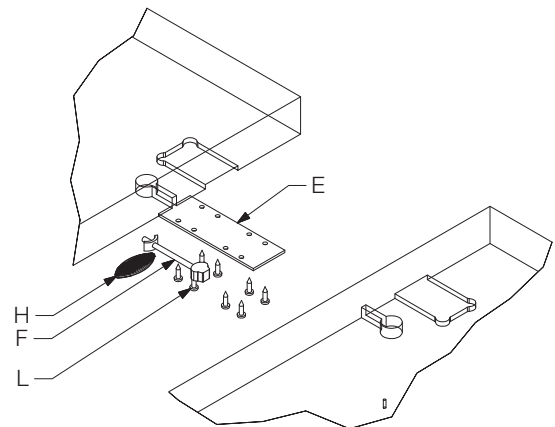

Detail H
for 2-piece tables

JD Media Table

4 Partial Media Wall Assembly (wall-mounted table option)

Note:

The partial media wall (S) is intended for use with the wall-mounted media table only.

4.1. (optional)

Supplied with each partial media wall is one (press-fit) round grommet with a 1-9/16" inside clearance used to channel cables from the floor direction. Grommet is field installed using a Ø1-3/4" hole saw in the location that best suits the end users application anywhere within the 19"H x 6-1/2"W grommet zone centred above the top, as detailed in the illustrations. If you are using this grommet and already know where you want to install it, you can do it now or wait until later, if you prefer.

4.2. Position the attachment panel portion of the partial media wall (N) resting and centred on the table top. Then using field drilled holes fasten it to the support wall.

Note:

It is the responsibility of the customer and its structural engineer/architect to specify the correct fasteners and method for attaching the media wall to the supporting wall and to confirm that the installers have adhered to these specifications. For all local building standards and codes, and additional requirements (including, but not limited to, seismic conditions) the customer should always consult local code agencies.

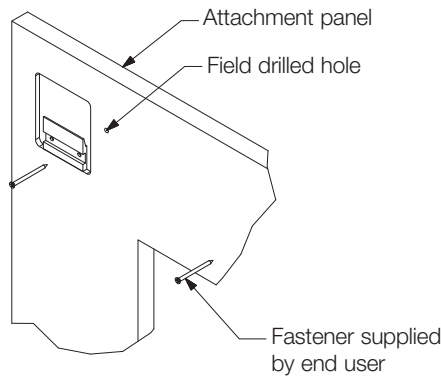

Detail K
Attachment panel

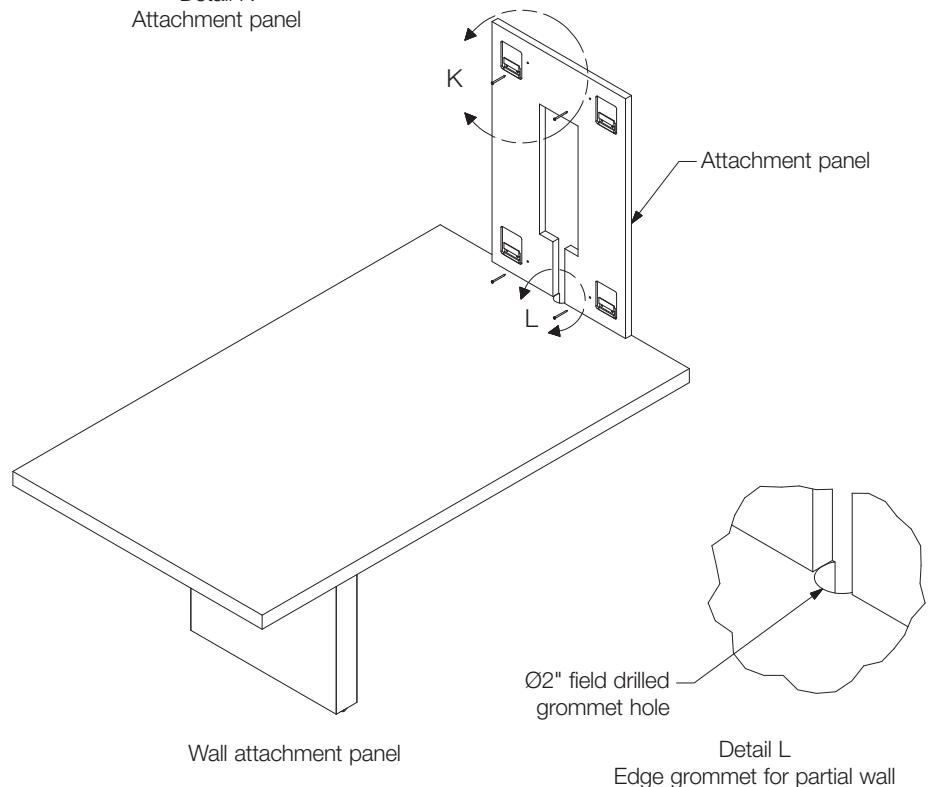

Wall attachment panel

Detail L
Edge grommet for partial wall

JD Media Table

4.3. Attach the finished cover portion of the partial media wall by engaging the wall cleats, as shown in detail M.

Note:

If you need to install the grommet and elected to not install it earlier in step 4.1, you can do it now.

4.4. Partial media wall assembly is now complete. Proceed to section 5 for "Power & Connectivity", if this option was selected.

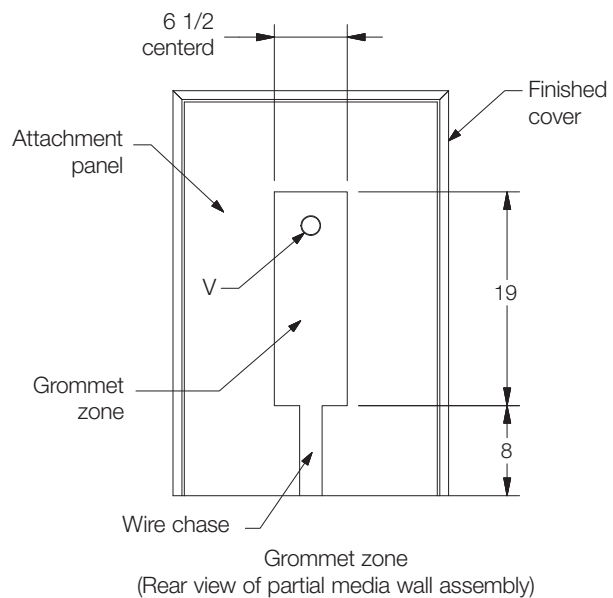
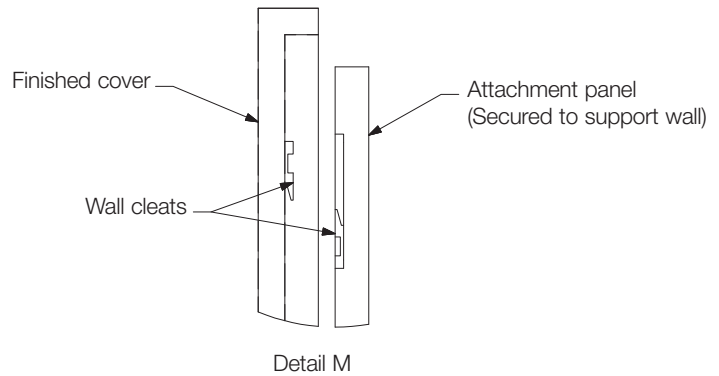
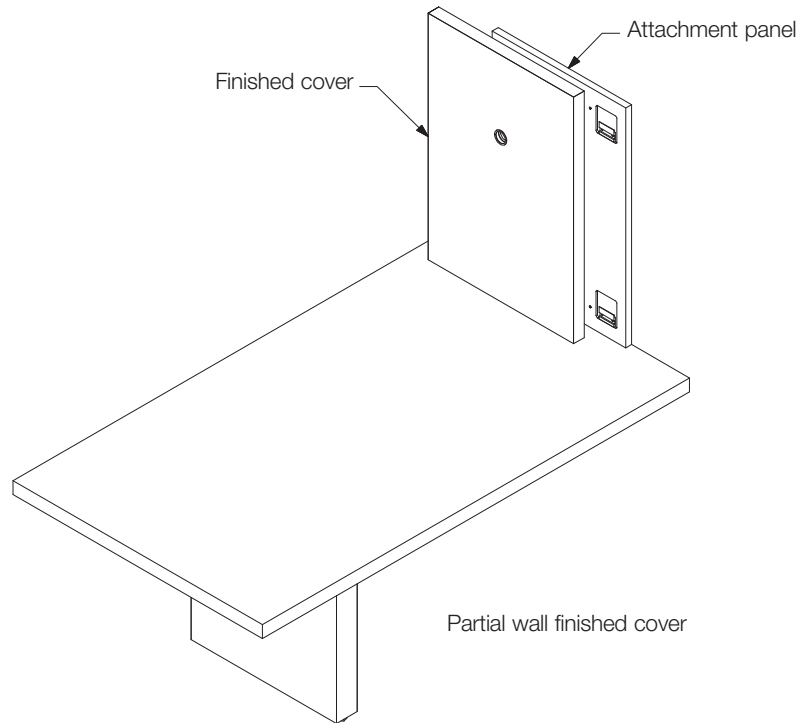

JD Media Table

5 Power & Connectivity

5.1. TABLETOP ELECTRICAL BOX

- 5.1.1. Install tabletop box (V) into the factory cutouts provided using the instructions included with the power units.
- 5.1.2. For installing extron components, see "Instructions 00D00002".
- 5.1.3. For cable management, see image "Cabling diagrams".

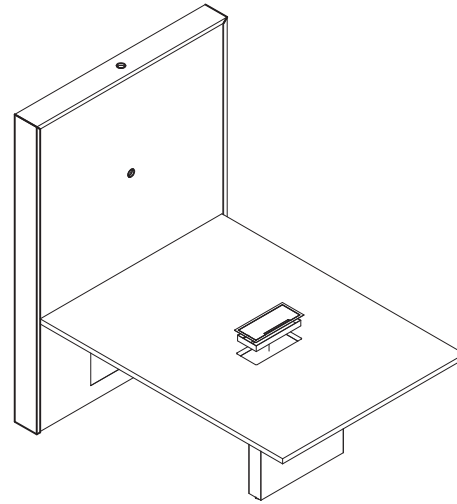

Tabletop power

5.2. SLIDE-OUT ELECTRICAL BOX

- 5.2.1. Using the instructions included with slide-out box (W), attach them to the underside of top (A) using the pilot holes to properly locate each unit as shown in detail P.
- 5.2.2. For installing extron components, see "Instructions 00D00002".
- 5.2.3. For cable management, see image "Cabling diagrams".

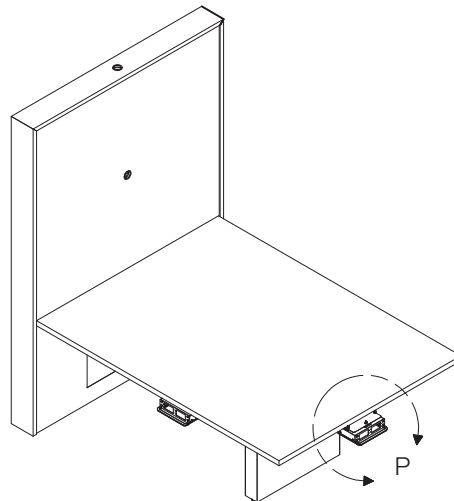

Slide-out power

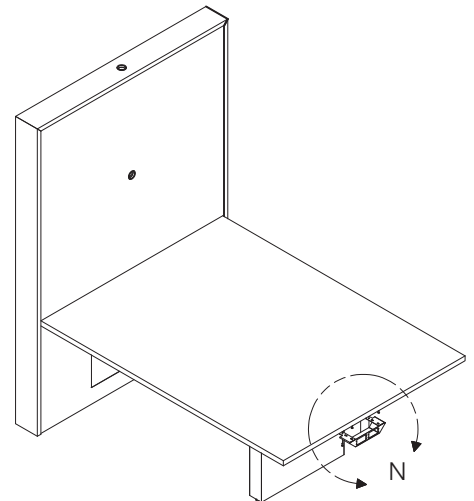

Under-mount power

5.3. UNDER-MOUNT ELECTRICAL BOX

- 5.3.1. Prepare top (A) to accept under-mount box (X) by loosely attaching fasteners (Y) into the pilot holes shown in detail N, stopping about 1/16" short from being fully tightened.
- 5.3.2. Attach under-mount box (X) to the underside of top (A) by engaging the keyholes with fasteners (R) loosely attached to the top in the previous step.
- 5.3.3. Lock the under-mount box (X) in place with fasteners (R) using the holes on rear tabs.
- 5.3.4. For installing extron components, see "Instructions 00D00002".
- 5.3.5. For cable management, see image "Cabling diagrams".

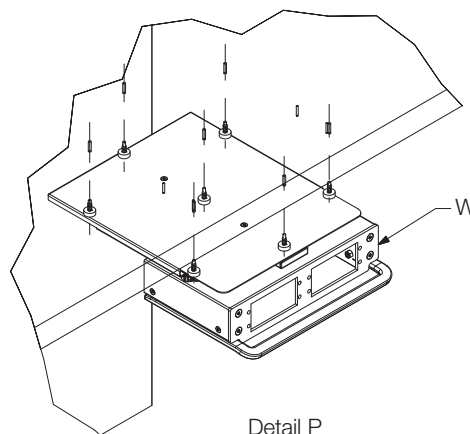

Detail P
Slide-out power

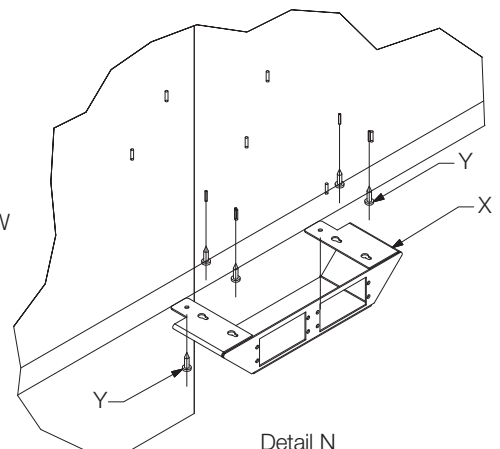

Detail N
Under-mount power

JD Media Table

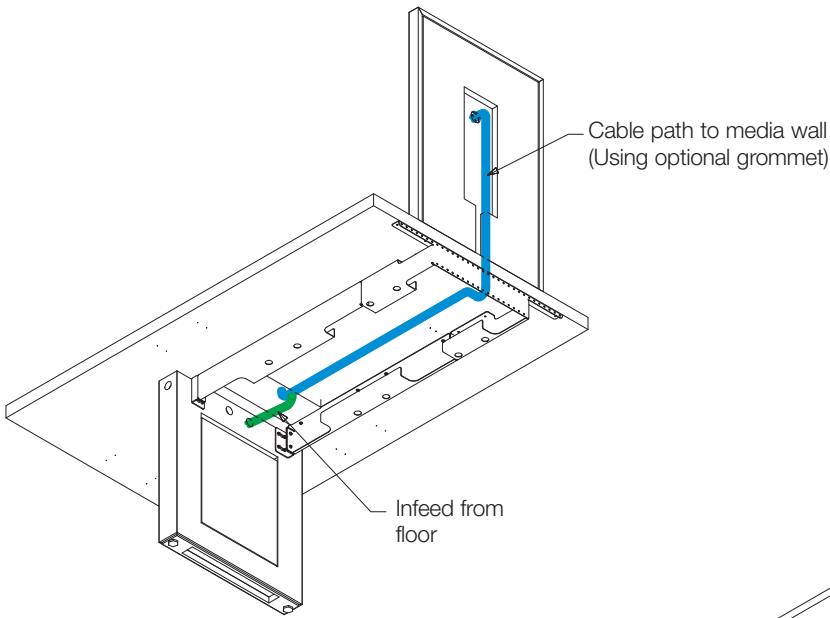

Cabling diagram:
Wall-mounted table and partial media wall
with tabletop power option

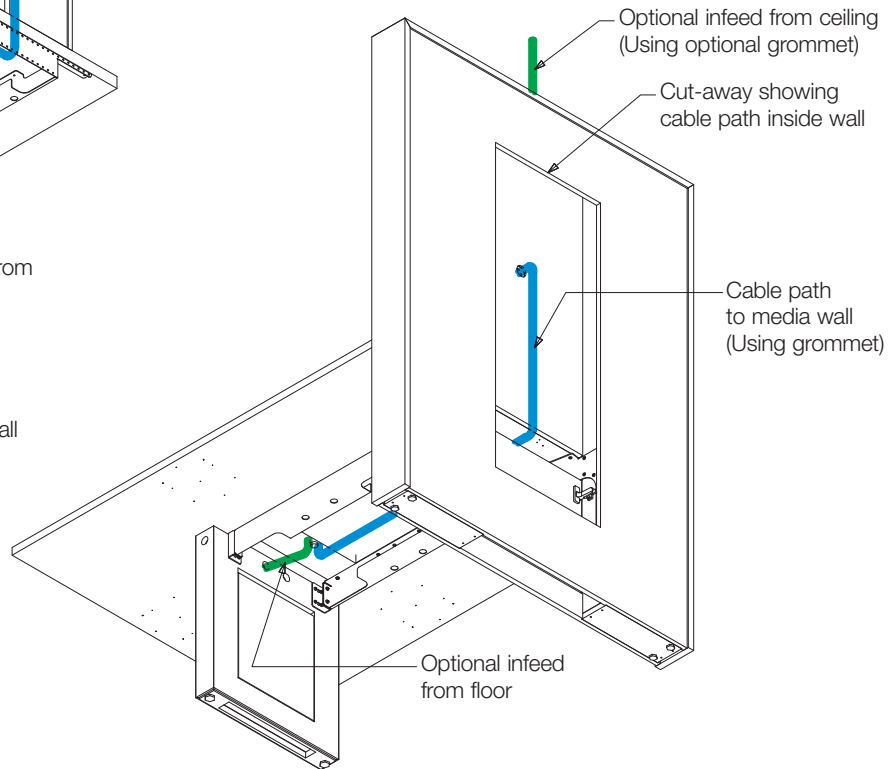

Cabling diagram:
Free-standing table and full media wall
with tabletop power option

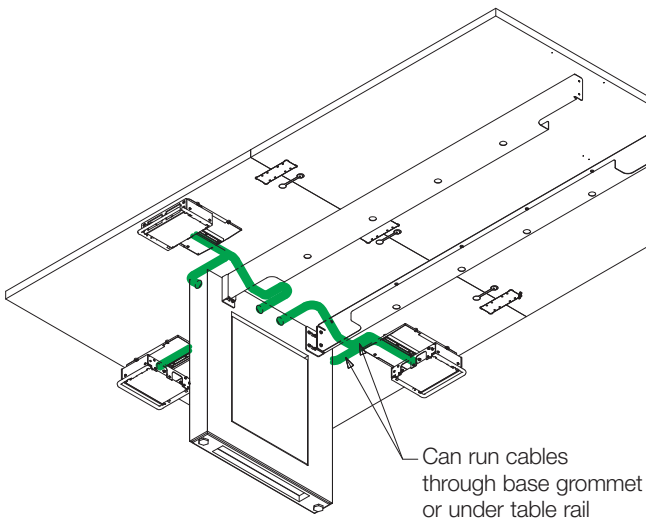

Cabling diagram:
Slide-out power option

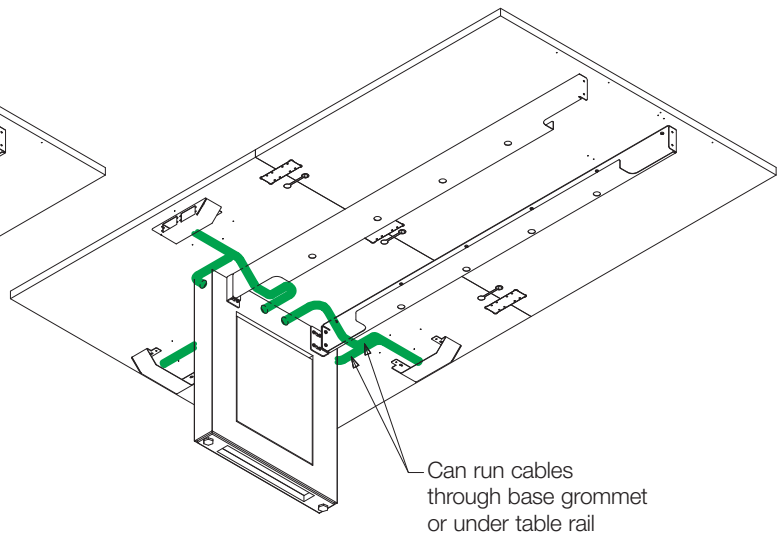

Cabling diagram:
Under-mount power option